



NILES®



INSTALLATION GUIDE



FOR USE IN HOME AUDIO OR
THEATER SYSTEMS HIGH PERFORMANCE
CEILING-MOUNTED PASSIVE SUBWOOFER
CM900SUB SERIES SUBWOOFER

CM900SUB *SERIES*

CONGRATULATIONS!

Thank you for choosing a CM900 series ceiling-mounted passive subwoofer from Niles. With proper installation and operation, you should enjoy years of trouble-free use.

Niles manufactures the industry's most complete line of custom installation components and accessories for audio/video systems. To see the complete Niles product assortment, visit us on the Internet at: www.nilesaudio.com

SPECIFICATIONS

CM950SUB

- *Recommended Amplifier Power*
10 to 150 watts per channel
- *Nominal Impedance*
6 ohm
- *Frequency Response*
33Hz - 140Hz +/-4dB
- *Sensitivity*
90 dB with 2.83 V pink noise input measured at 1 meter on axis
- *Frame Dimensions*
12-3/4 inches
- *Hole Cut-Out Dimensions*
11-1/4 inches
- *Depth Behind Ceiling*
6-5/8 inches
- *Wiring Requirements*
We recommend using 16-gauge subwoofer wire for runs up to 80 feet and 14-gauge subwoofer wire for runs up to 200 feet. The connectors will accommodate 12 to 22-gauge wire.

CM960SUB

- *Recommended Amplifier Power*
10 to 150 watts per channel
- *Nominal Impedance*
6 ohm
- *Frequency Response*
30Hz - 140Hz +/-4dB
- *Sensitivity*
91 dB with 2.83 V pink noise input measured at 1 meter on axis
- *Frame Dimensions*
12-3/4 inches
- *Hole Cut-Out Dimensions*
11-1/4 inches
- *Depth Behind Ceiling*
6-5/8 inches
- *Wiring Requirements*
We recommend using 16-gauge subwoofer wire for runs up to 80 feet and 14-gauge subwoofer wire for runs up to 200 feet. The connectors will accommodate 12 to 22-gauge wire.

INSTALLATION CONSIDERATIONS

We recommend using the following tools and material to install your Niles CM900 series subwoofer:

- A minimum of two runs of 16-gauge two conductor subwoofer wire or one run of the same size four conductor subwoofer wire
- Rubber gloves and protective eyewear
- Keyhole or drywall saw
- Phillips screwdriver set
- Electric drill with 1/4 – and 1/2-inch drill bits and a 1-inch flat drill bit (for drilling through studs)
- Wire stripper
- Stud finder
- Cable ties
- Stiff wire, fish tape or glow rods for routing cables
- Pencil

Before starting the installation, please observe the following precautions:

- Turn off all system power before making any connections
- Always wear protective eyewear when using tools
- Make sure hands are clean before installation
- Wear gloves when working with fiberglass insulation

RUNNING WIRES IN WALLS OR CEILINGS

When running subwoofer wire inside walls or ceilings, use special jacketed cable (CL-2 or CL-3) to protect the wire and for fire prevention. In some areas, conduit is also required. For a trouble-free installation, low-voltage wire such as subwoofer wire must be run in accordance with the National Electrical Code and any applicable provisions of the local building code. If you are unsure of the correct installation techniques, wire jacket, or type of conduit to use, consult a professional audio/video installer, building contractor, or the local building and inspection department.

SELECTING THE NUMBER AND LOCATION FOR YOUR SUBWOOFER

The CM900 series passive subwoofers are designed to be installed in any standard ceiling. There are two considerations for placing the subwoofer; ease of running the cable to the desired location and the effect that placement may have on performance. Installing the subwoofer in a corner position will enhance the perceived bass output to some listeners, but may also produce a “boomy” sound.

INSTALLING WITH SATELLITE SUBWOOFER

A concealed CM900 series subwoofer installation allows you to enjoy your entertainment system with full range sound even if your satellite subwoofers are small. When used with satellite subwoofers that have substantial bass of their own, the CM900 series subwoofer will augment the bass performance. A typical installation is illustrated below. It is possible to control the volume of the sound of both the subwoofer and the satellite subwoofers simultaneously. The volume control is connected in-line with the subwoofer. An example of wiring an area that has 1 subwoofer and 2 loudspeakers installed with a master volume control is shown in **Figure 1**. In addition to controlling the volume of the subwoofers, these controls allow the addition of added loudspeakers without adding more amplifier channels. Niles manufactures a wide variety of volume controls and other accessories that can suit virtually any of your needs.

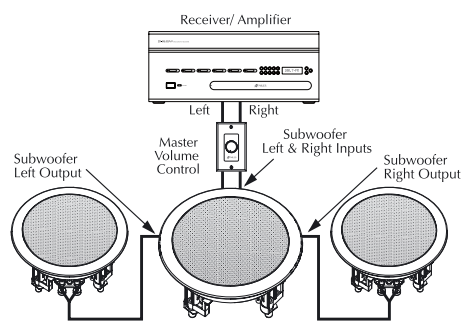
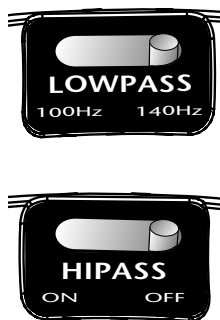

Figure 1. 1 Subwoofer and 2 satellite loudspeaker using one master volume control



INSTALLATION

1. The CM900 series subwoofers feature a separate frame assembly which installs with four clamps or mounting “dogs” which hold the frame in place. The dogs are tightened via four front-baffle screws. Tighten the dogs by turning the screws clockwise. **DO NOT OVERTIGHTEN THESE SCREWS.** Over-tightening the clamps may make the grille difficult to install.

NOTE: THE SCREWS WILL TURN EASIER IF YOU “PRIME” THEM FIRST. BEFORE INSTALLING EACH SUBWOOFER, TURN THE SCREWS IN AND THEN TURN THEM BACK OUT TO THEIR ORIGINAL POSITIONS.

2. At each subwoofer location, route the wire through the installed frame, then separate the subwoofer wire so that at least 2 inches of each conductor are free. Strip away 1/4 inch of insulation from each subwoofer wire.
3. On each set of subwoofer connectors, press down the spring-loaded connector, insert the appropriate conductor, and then release the connector. Gently tug on the subwoofer wire to make sure it is held in place. If not, repeat this procedure until it is. (See **Figure 2**).

NOTE: OBSERVE CORRECT POLARITY: POSITIVE (+) GOES TO THE RED POST AND NEGATIVE (-) GOES TO THE BLACK POST.

4. Holding the subwoofer in the palm of your hand, insert it into the frame and twist clockwise using the two molded tabs. This will lock it into the frame. (See **Figure 3**).
5. Connect the other end of each subwoofer wire to the receiver (or amplifier) in the same way.
6. Adjust high pass and low pass crossover switches if desired.

IMPORTANT: DO NOT OVER TIGHTEN THE SCREWS! OVER TIGHTENING THEM MAY MAKE THE GRILLE DIFFICULT TO INSTALL

PAINTING THE GRILLE AND FRAME

Each CM900 series subwoofer frame and flush-mount metal grille may be painted without the need for primer. For best results when painting the grille, use a spray gun or airless sprayer, thin the paint to prevent clogging of the grille holes, and apply several light coats instead of one heavy one.

- Install subwoofer frame into ceiling
- Paint the frame of the subwoofer
- Paint the grille separately from the subwoofer frame
- Install subwoofer into frame after the paint is dry
- Install grille after paint is dry

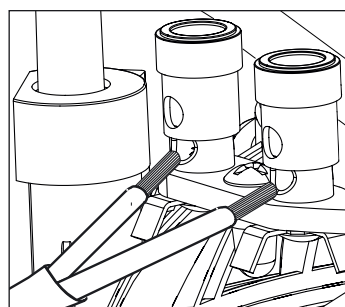

Figure 2. Subwoofer connectors

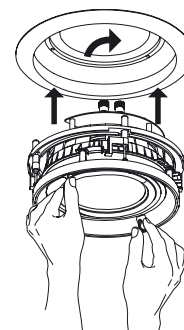

Figure 3. Installing the subwoofer



BLENDING HIGH FIDELITY AND ARCHITECTURE®

Niles Audio Corporation
12331 S.W. 130 Street Miami, Florida 33186
305-238-4373 Fax: (305) 238-0185
www.nilesaudio.com

©2006 Niles Audio Corporation. All rights reserved. Niles and the Niles logos are registered trademarks of Niles Audio Corporation. All other trademarks are the property of their respective owners. DS00541A